

# Measurement of the color ( $L^*a^*b^*$ ) of plastic recyclates by means of the laboratory device SPECTRO-3-0°/45°-MSM-LAB-ANA-P



## 1. Press article

First of all, with regard to the status of the plastics recycling quota, reference should be made to articles and contributions from German-speaking countries:

**320° Deutschlands Online-Magazin für die Circular Economy:**

**„Recyclingfähigkeit: Versprechen für 26 Kunststoffprodukte in EU**

**Bis 2025 sollen in Europa jährlich zehn Millionen Tonnen recycelte Kunststoffe hergestellt werden. Dazu hat sich die europäische Allianz für Kunststoffrecycling verpflichtet. ... 27. September 2021“**

**Statista: Kunststoffabfallaufkommen und recycelte Menge Kunststoff in Europa in den Jahren 2006 bis 2020 (in Millionen Tonnen)**

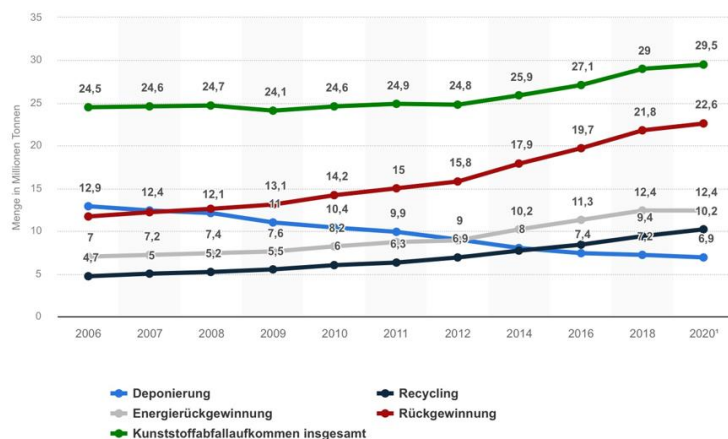

© Statista 2021

## **Hintergrundpapier: Plastikpolitik in Deutschland und der EU**

*Aktuelle Gesetze und Initiativen, Ecologic Institut, Juli 2020*

<https://bmbf-plastik.de/de/publikation/hintergrundpapier-plastikpolitik>

*„... Für Verpackungsabfälle aus Kunststoff werden folgende Recyclingziele gesetzt:*

*>> 50 Gewichtsprozent bis 2025*

*>> 55 Gewichtsprozent bis 2030 ...“*

### ➤ **RECYCLING** magazin:

#### **Kunststoffrecycling in Europa muss massiv ausgebaut werden**

*„... Das Recycling von Kunststoffen in Europa befindet sich im Umbruch. Einerseits erhöhen sich die Anforderungen an dieses Recycling beständig. Andererseits stehen Handel und Industrie von Verbraucherseite aus zunehmend unter Druck, mit Kunststoffen verantwortlich umzugehen.*

*Vor diesem Hintergrund wurden auch die gesetzlichen Anforderungen in der EU erhöht. Für Kunststoffverpackungen etwa steigt die gesetzlich vorgeschriebene Recyclingquote in der EU auf 55%. ... Das würde wiederum bedeuten, dass – bei stabilen Konsummengen – die Menge der in der EU produzierten Kunststoffzyklate von geschätzt knapp 5 auf 11 Millionen Tonnen jährlich ansteigen müsste. ...“*

<https://www.recyclingmagazin.de/2020/07/01/kunststoffrecycling-in-europa-muss-massiv-ausgebaut-werden/>

### ➤ **KUNSTSTOFFE** 10/2021:

#### **Der lange Weg zur Kreislaufwirtschaft**

##### **Die Schwierigkeiten beim Kunststoffrecycling überwinden**

*„... Nach Zahlen des europäischen Verbands der Kunststoffhersteller PlasticsEurope hat sich etwa die Menge des in der Europäischen Union (einschließlich Norwegen und der Schweiz) aufbereiteten Post-Consumer-Abfalls von 2006 bis 2018 verdoppelt. Sie stieg von 4,7 auf 9,4 Mio. t. Deponiert wurden 2018 noch 7,2 Mio. t. Der größte Teil der ausrangierten Post-Consumer-Kunststoffe in der EU, 12,4 Mio. t., landet in der thermischen Verwertung. ...“*

Ein PDF des Artikels unter [www.kunststoffe.de/onlinearchiv](http://www.kunststoffe.de/onlinearchiv)

## **2. Increasing need for quality control of plastic recyclates**

As can be seen from the cited articles and technical papers, the recycling rate in the EU for plastic packaging will initially rise to 50% by 2025 and then to 55% by 2030. For recycling companies, the technical effort required to achieve and maintain these quotas is increasing disproportionately, as consumers' expectations of high-quality and visually flawless recycled packaging are also rising. The laboratory instrument described below is intended to help monitor as well as document the color progression of the recyclates. The idea is to take samples from the recyclate stream at regular intervals and then measure them for color using the SPECTRO-3-0°/45°-MSM-LAB-ANA-P laboratory instrument. The device displays the color value in L\*a\*b\* as well as the color deviation from the specified reference. Furthermore, each sample is documented and can be provided with a label indicating the respective date, time and L\*a\*b\* - and dL\*da\*db\* - values.

### 3. Design of the colorimeter SPECTRO-3-0°/45°-MSM-LAB-ANA-P

#### 3.1 Measuring principle

The so-called 0°/45° method is used here, whereby the sample is illuminated under 0° and observed under 45°. For this purpose, the recycle is arranged behind a glass pane, the distance from the sensor head to the recycle is therefore constant. A recycle surface with a diameter of approx. 20mm is illuminated and observed, thus a certain optical averaging is achieved, the slightly different position of the pellets from

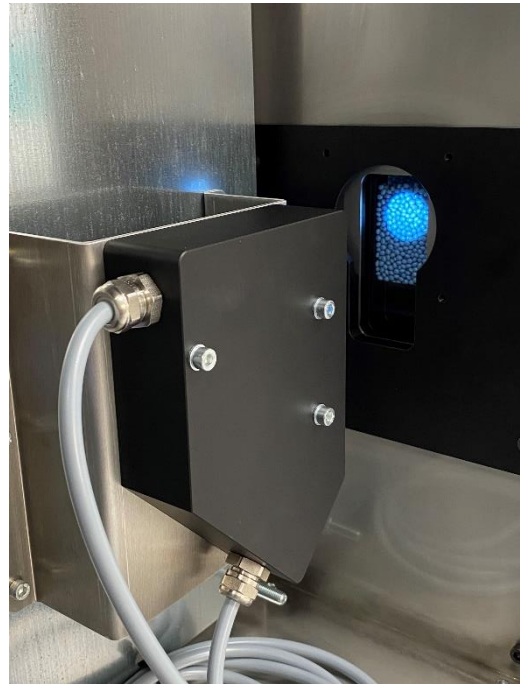
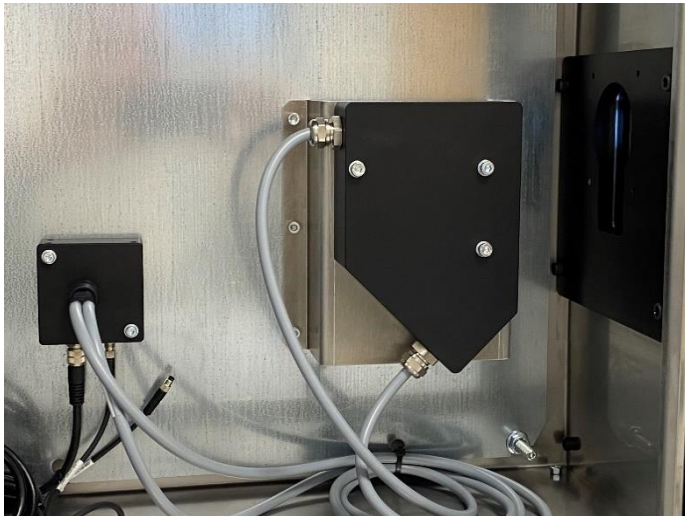

measurement to measurement then no longer has a significant influence on the measurement result.

The measuring system is divided into an optical front end and an evaluation unit. The optical front end is connected to the color evaluation unit via two optical fibers (transmitter and receiver strand).

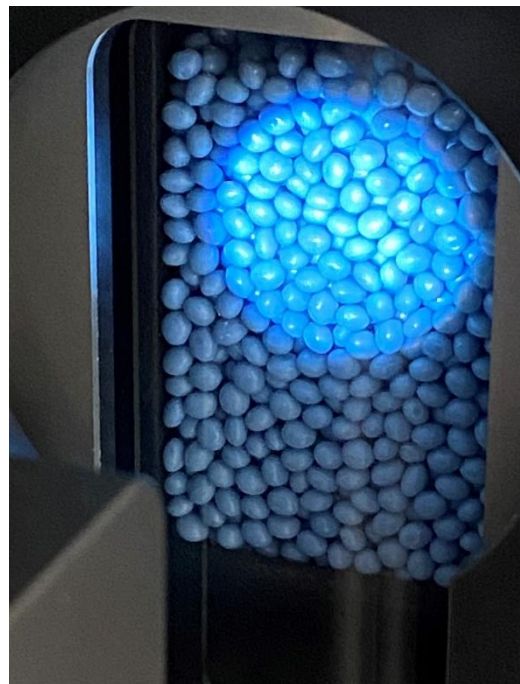
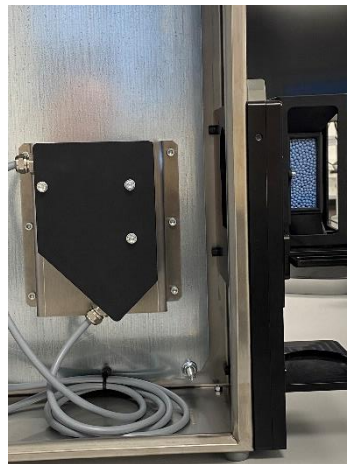

The color evaluation unit has an RS232 interface and is connected to a panel PC via an RS232/USB converter. The pellets are placed by means of a hopper unit as tightly packed as possible in front of the 15mm thick glass pane that separates the interior from the exterior. After the measurement has been completed, the sample is filled back into the sample container by means of a slider. For the calibration of the measuring system, RAL plastic cards are used. Care should be taken to ensure that the color of the cards used is approximately the same of the pellet samples. To do this, the pellet funnel is removed from the measuring system and the RAL plastic cards can then be inserted one by one into the opening provided for this purpose. By means of DOCAL software and after selecting the CALIB menu item, the operator is guided through the calibration process.

### 3.2 The measurement system

Essentially, the measuring system consists of the following components:

- Evaluation unit (panel PC, sensors, calibration card holder, holder for the pellet sample container, pellet hopper unit with sight glass, slider, +24V power supply, USB interface, ON/OFF switch, Ethernet interface).
- Label printer
- Pellet sample container
- RAL – plastic calibration cards
- keyboard
- mouse

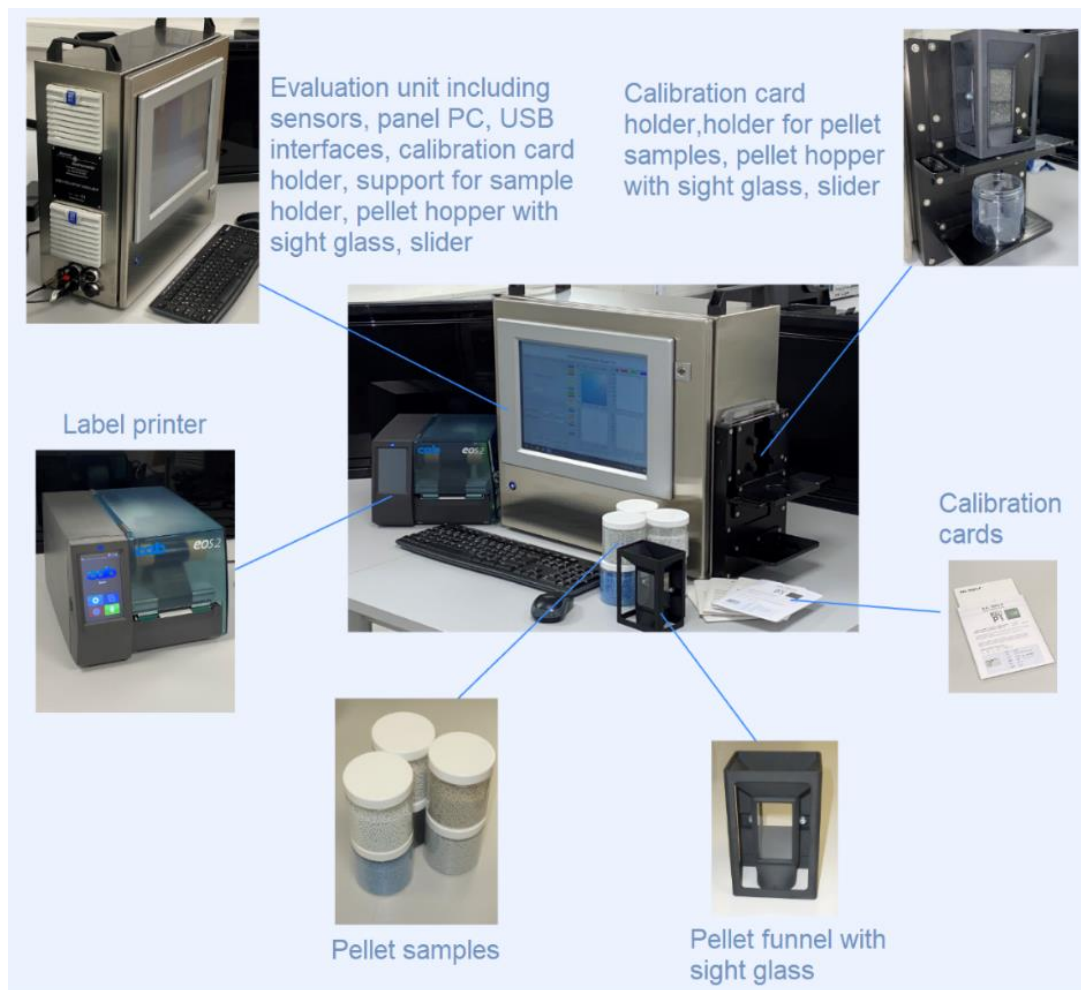

#### 3.2.1 Evaluation unit

The stainless-steel housing accommodates the color sensor system (front end and color evaluation unit), the panel PC, the ON/OFF switch, the USB interfaces, the Ethernet interface, the round plug for connecting the +24V power supply and furthermore the calibration card holder incl. slider, pellet sample container holder and glass plate are permanently connected to the housing. The funnel unit incl. sight glass for pellet pick-up can be flanged to this unit (calibration card holder unit) after calibration has been completed, for measuring the color of the recyclate.

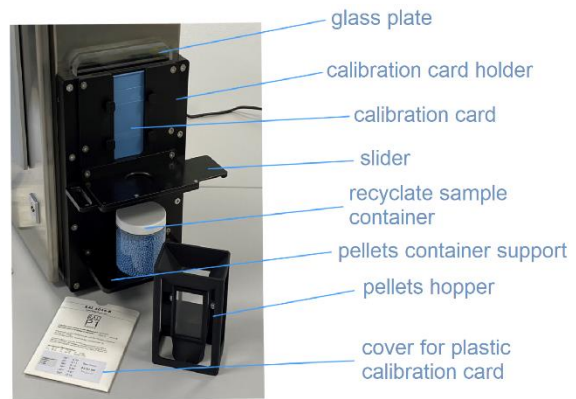

Pictures: Evaluation unit incl. calibration card holder unit, glass plate, pellet hopper unit, calibration card incl. sleeve, recyclate sample container, +24V power supply, keyboard and mouse

### 3.2.2 Calibration card holder unit incl. glass plate, slider and pellet sample container holder

#### 3.2.2.1 Calibration card holder unit without pellet hopper unit

The calibration card holder unit attached to the side of the stainless-steel housing enables calibration

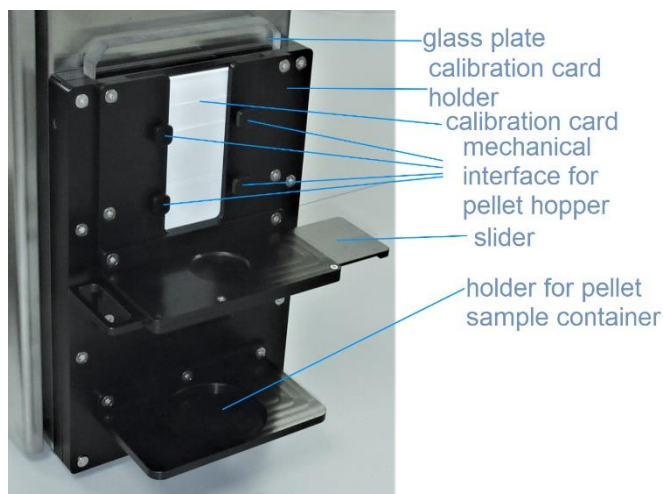

of the color sensor to the respective calibration card. The glass plate is located directly in front of the calibration card and between the calibration card and the color sensor. After calibrating the sensor system to the RAL plastic cards (calibration cards) in question, the calibration card still in the calibration card holder unit placed on it instead.

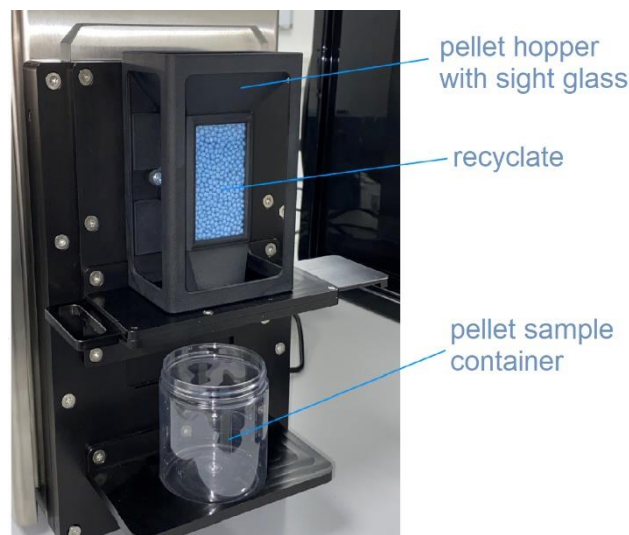

#### 3.2.2.2 Calibration card holder unit with pellet hopper unit



After the pellet hopper unit is flanged to the calibration card holder unit, the recyclate can be filled into the space formed by the pellet hopper unit and the glass plate via the funnel. The recyclate can be observed through the sight glasses integrated into the pellet hopper unit. In addition, the pellets almost completely fill the interior space between the glass plate and the pellet hopper unit. The pellets are thus packed as tightly as possible directly against the glass side facing the pellet hopper unit.

### 3.2.3 Calibration cards



RAL plastic cards are used for calibration. Since these were measured in the factory (RAL) according to the d/8° method (diffusely illuminated and observed under 8° to the normal), whereas the color sensor system used in the laboratory instrument is based on the 0°/45° method, the available plastic cards were re-measured according to the 45°/0° method using a calibrated hand-held device; the corresponding L\*a\*b\* values were subsequently attached to the respective plastic cards as well as card sleeves by means of labels.

In addition, a file was created in which an assignment of the RAL numbers was made with regard to the corresponding L\*a\*b\* values:

-  RAL Plastic Plate measured with Hunter Lab - 45°\_0°
-  RAL Plastic Plate Standard d-8°

Examples of some RAL plastic cards with additionally attached label (L\*a\*b\* - 0°/45°):



### 3.2.4 Pellet sample containers and recyclates

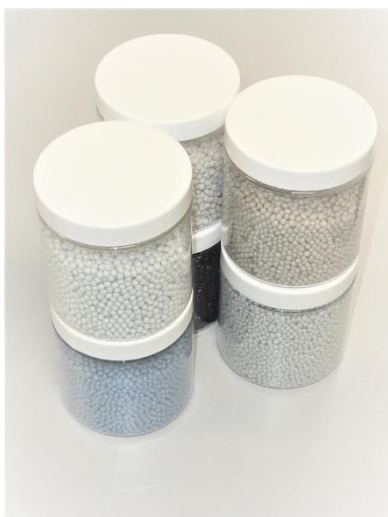

For the respective recyclates to be tested, pellet sample containers are available which have been selected in terms of dimensions so that they both fit into the sample holder provided in the calibration card holder unit and, in addition, the amount of recyclate in the sample containers perfectly matches the volume of the pellet hopper unit. 12 of these containers are included in the scope of delivery for each laboratory unit. However, these containers can also be reordered as separate items, should they be used to store the recyclate samples, provided with label (date, time, L\*a\*b\*, dL\*da\*db\*).

### 3.2.5 Label printer



A printer of type „cab eos2“ is used as label printer. The label printer is preset at the factory so that the interface driver, the label format and the label roll are suitable for this application. The connection to the laboratory device is established via a USB interface cable.

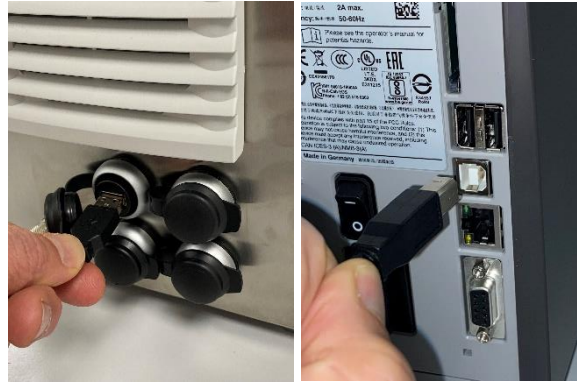

### 3.2.6 Software

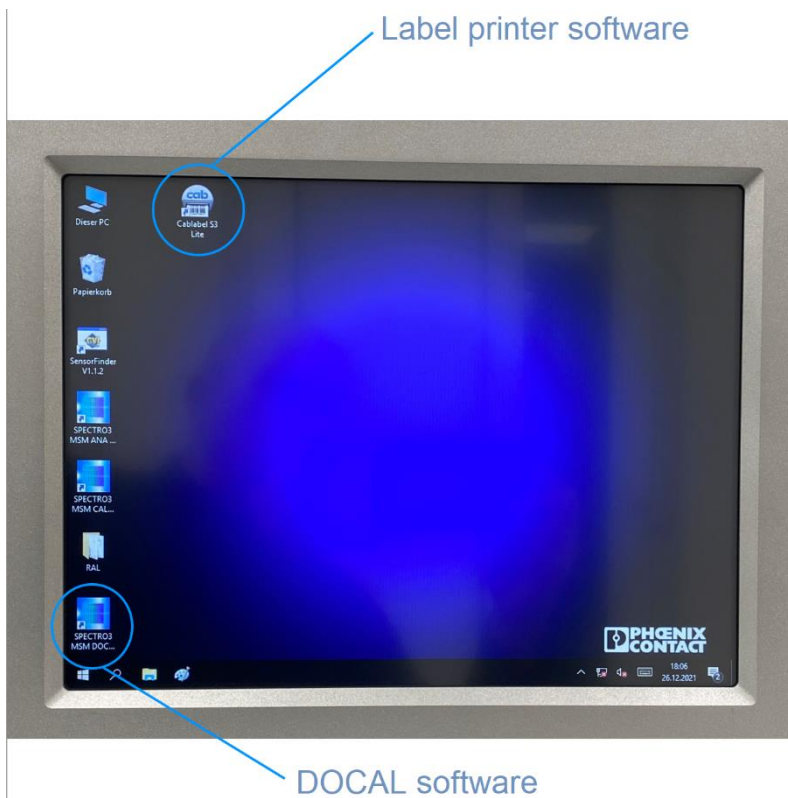

Both the Cablabel S3 Lite software for the cab eos2 label printer and the *SPECTRO3 MSM DOCAL Scope V1.0* software for the *SPECTRO-3-FIO-MSM-ANA-DL* color sensor are already installed on the evaluation unit at the factory.

Furthermore the files for the RAL plastic cards as well as the printer driver for the label printer are on the computer. The *SPECTRO3 MSM ANA Scope V3.3* and the *SPECTRO3 MSM CALIB Scope V1.0* software are also installed on the panel PC. By means of the *SensorFinder V1.1.2* software the used interfaces can be queried. However, there is usually no need for the user

to access any software other than the *SPECTRO3 MSM DOCAL ScopeV1.0*; rather, these are provided for any service use.

## 4. Commissioning of the SPECTRO-3-0°/45°-MSM-LAB-ANA-P laboratory instrument

### 4.1 Connection of the device to the 220V mains

The connection to the 220V socket is done via the external +24V power supply included in the delivery (INPUT: 100-240V AC 47-63Hz 1.9A OUTPUT: +24V DC 3.3A max.). The +24V power supply is connected to the laboratory device via the 3-pin round plug:



### 4.2 Connection of the label printer *cab eos2* to the 220V mains supply

The label printer can be connected directly to the 220V mains (100-240V AC 2A max. 50-60Hz) with the included power cable.



### 4.3 Connecting the laboratory device to the label printer via the USB interface

The laboratory device is connected to the label printer via the 1.8m long USB cable included in the scope of delivery.





#### 4.4 Switching on the laboratory device

The laboratory unit can be switched on via the pressure switch on the front of the unit. The blue LED in the pressure switch indicates that the evaluation unit is in operation. Furthermore, the Panel PC and the Panel PC monitor are activated.

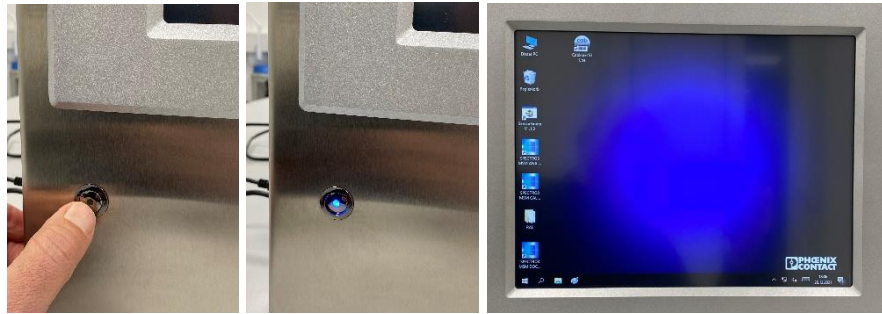

#### 4.5 Label roll verification

Before the label printer is put into operation, you should take a look at the two rolls (black and white roll, type TF Satin White 50x30 article-no. 5780036) in the printer. Replacement rollers can also be reordered via Sensor Instruments GmbH.



#### 4.6 Switching on the label printer

The label printer can be switched on using the toggle switch on the back of the device.



#### 4.7 Activating the SPECTRO3 MSM DOCAL Scope V1.0 Software

A mouse click on the SPECTRO3 MSM DOCAL icon (bottom left on the start screen) activates the SPECTRO3 MSM DOCAL Scope V1.0 software.

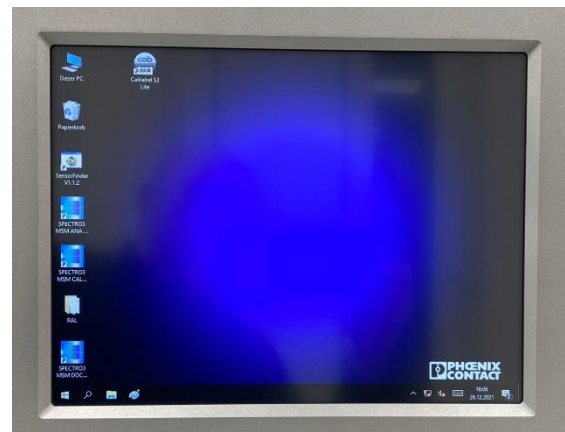

## 5. Calibration of the laboratory unit

Before you can start measuring, you must first calibrate the laboratory instrument (in this case, specifically the color sensor system). Calibration is performed with the help of RAL plastic cards.

In addition to one of the three white RAL plastic cards (RAL9003-P, RAL9010-P or RAL9016-P), RAL plastic cards that visually resemble the recyclates to be tested should be used if possible.

In the following example, in addition to RAL9003-P, calibration is to be performed on 4 further RAL plastic cards:

- RAL9002-P
- RAL7035-P
- RAL5024-P
- RAL9011-P

The PARA1 Windows® interface is used to start the program. The *AVERAGE* value should be set to 8096. After entering the value, click the *EE* field with the mouse pointer and then click the *SEND* software button. In the next step, click on the *CALIB* menu item. The *CALIB* Windows® interface opens. After clicking the *START CALIBRATION ASSISTANT* software button, the operator is prompted to insert one of the white reference cards (RAL9003-P, RAL9010-P or RAL9011-P) into the calibration card slot: in our example **RAL9003-P**, then confirm two times with *OK* (confirm both of the following *Message!* Windows® interfaces by clicking on *OK*).

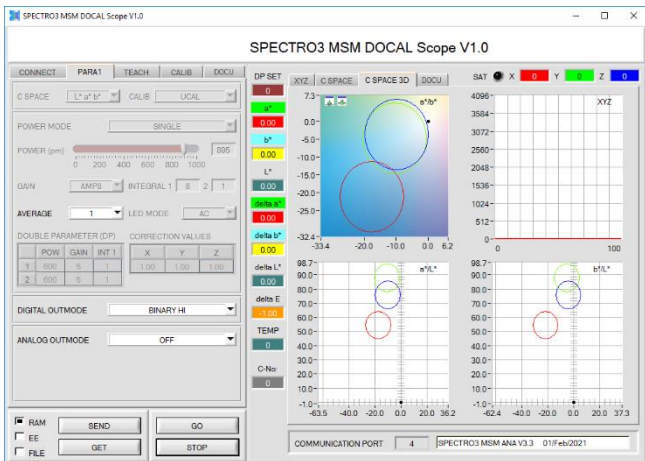
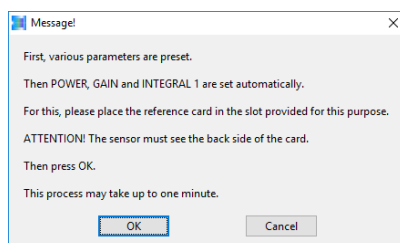
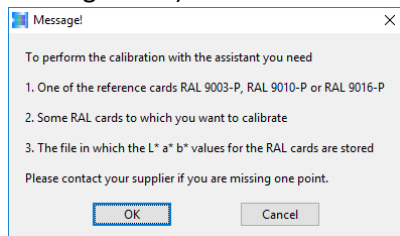

CALIB REF		CALIB DATA		SENSOR DATA		
REFERENCE SETVALUE						
L*	a*	b*	X SI	Y SI	Z SI	RAW X
0.0000	0.0000	0.0000	0	0	0	RAW Y
CALCULATED XYZ OF REF						
X	Y	Z	Xn Yn Zn	Yn 100	Zn 108.9	RAW Z
0.0000	0.0000	0.0000	Xn 95.05	Yn 4096	Zn 4096	0

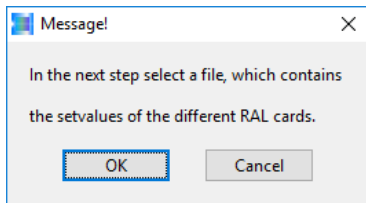

After clicking this OK button, the following Windows® interface opens:

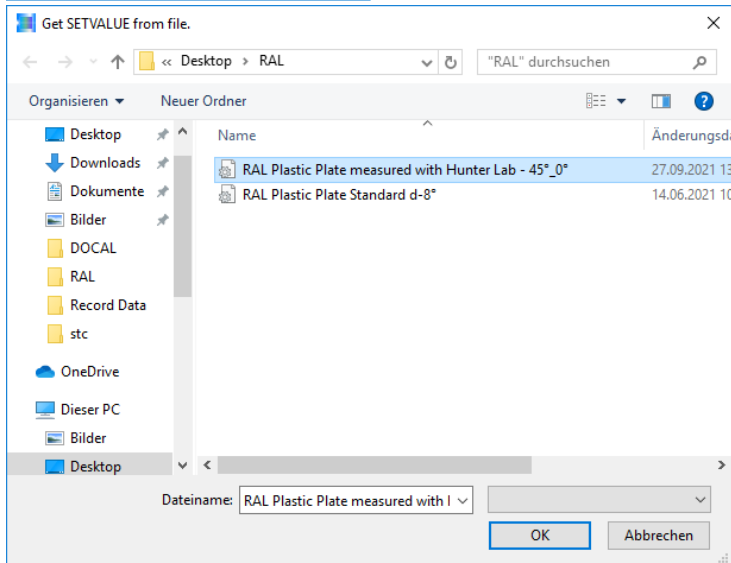

Clicking the *RAL Plastic Plate measured with Hunter Lab - 45°\_0°* row and confirm with OK.

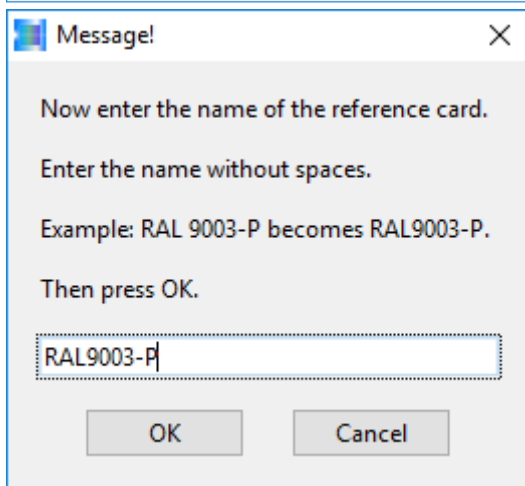

In the button that opens, the name of the RAL plastic card that is now in the calibration card holder is entered: *RAL9003-P*

After confirming with the OK software button the L\*a\*b\* values for RAL9003-P from the file (RAL Plastic Plate measured with Hunter Lab - 45°\_0°) are entered into the SET VALUE TABLE and at the same time the XYZ color values of the SPECTRO-3 color sensor are inserted into the ACTUAL XYZ VALUE TABLE. The software then asks for other RAL plastic cards to be used:

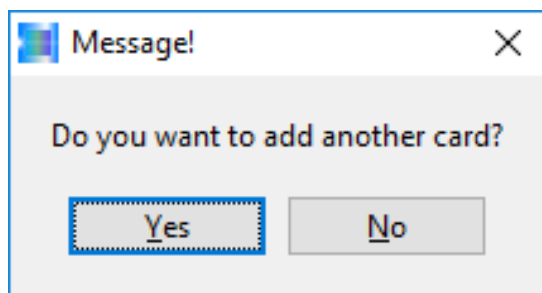
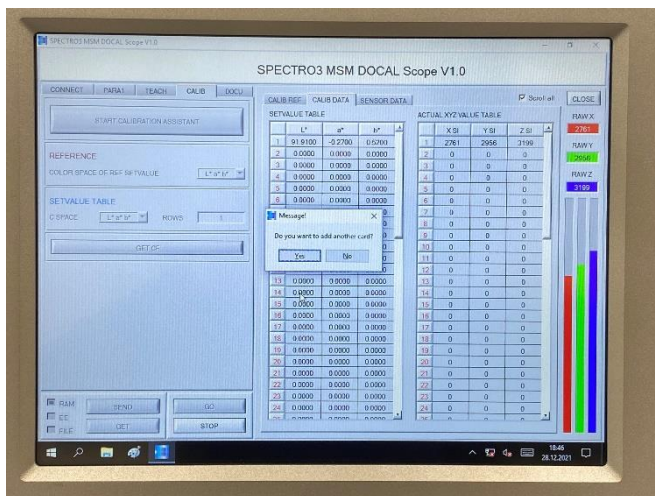

After clicking the Yes software button the software is ready to enter new RAL plastic cards:

**RAL9002-P**

# Calibrate RAL9002-P

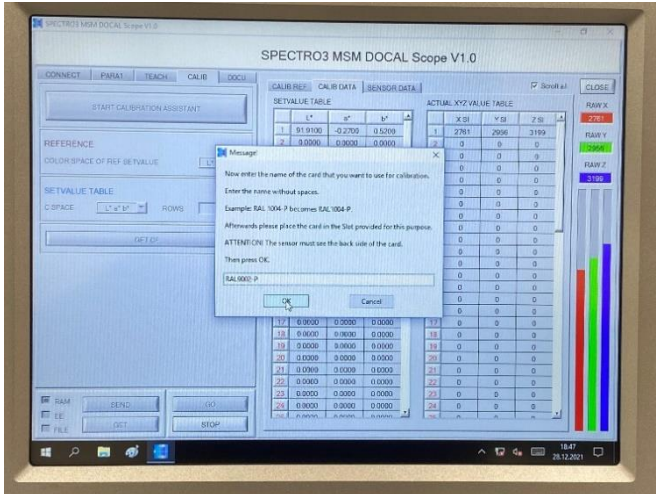

Remove the RAL9003-P plastic card from the calibration card holder and insert the RAL9002-P plastic card into the calibration card holder. After clicking the OK button twice, the

calibration to RAL9002-P is performed, i.e. the software takes over the L\*a\*b\* values from the file *RAL Plastic Plate measured with Hunter Lab - 45\_0°* and enters them into the SETVALUE TABLE as well as the

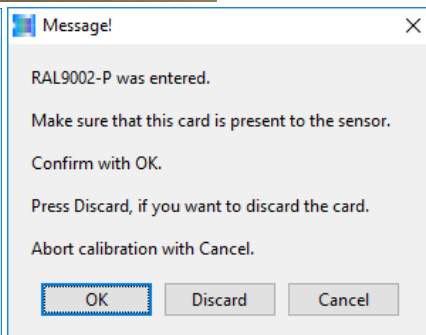
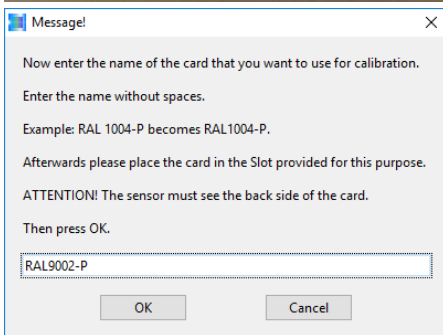

current XYZ values of the colorimeter into the ACTUAL XYZ VALUE TABLE in the second row of the respective table. The software now asks for **another calibration** card, in our example the **RAL7035-P**. First remove

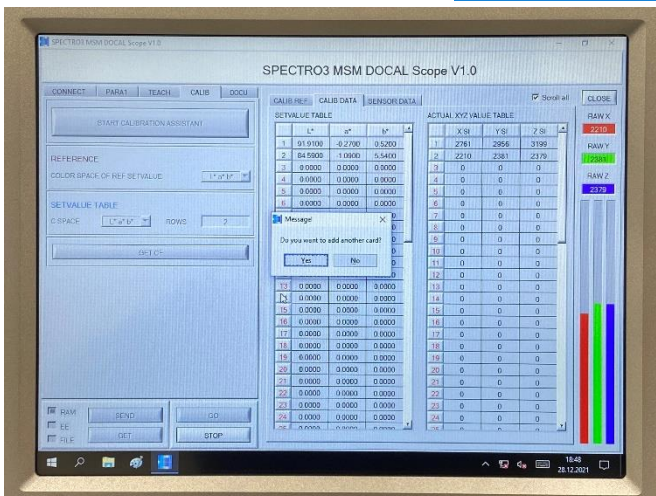

the RAL9002-P from the calibration card holder and insert the RAL7035-P into the calibration card holder and confirm with OK in the software. Then enter the new calibration card: *RAL7035-P* and confirm with OK.

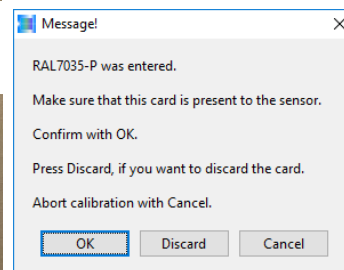
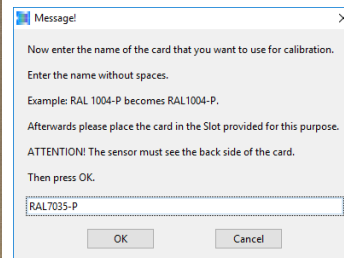

The software then inquires whether the RAL7035-P is placed. Confirm with OK (mouse click).

The L\*a\*b\* values are inserted into the SETVALUE TABLE and the current XYZ values into the ACTUAL XYZ VALUE TABLE in the 3<sup>rd</sup> row of the respective table.

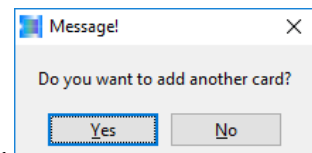
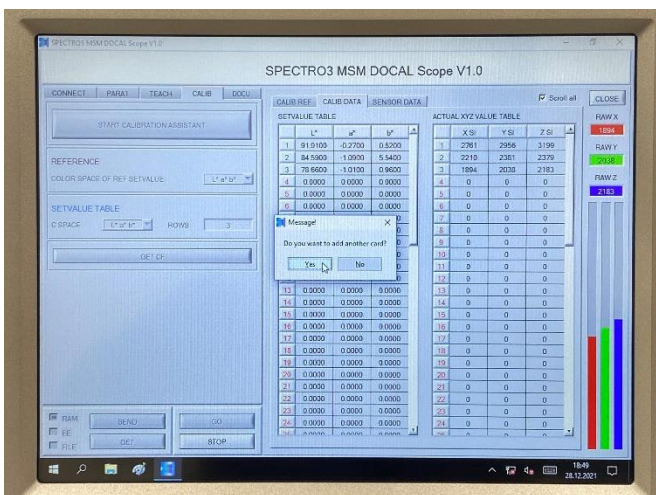

In our example we now continue with the **RAL5024-P** plastic card. After clicking the Yes – button in the *Message!* window enter **RAL5024-P** and confirm with **OK**.

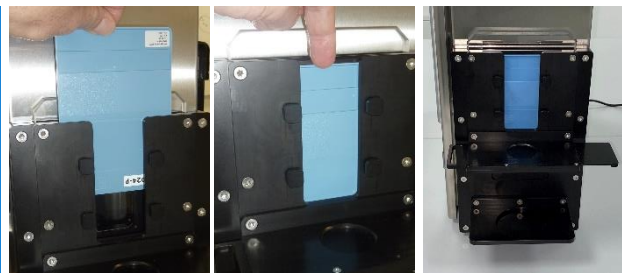
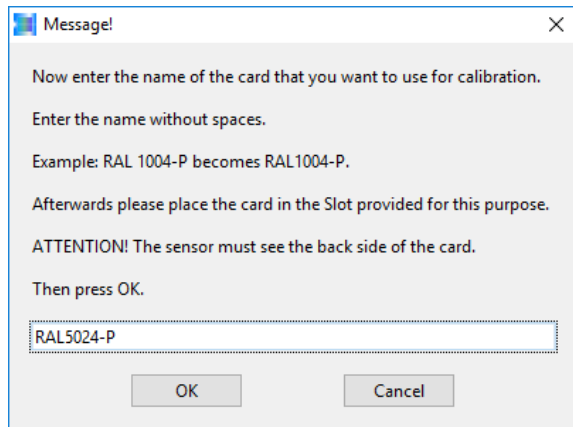

After making sure that the RAL5024-P plastic card is in position, acknowledge again by clicking **OK** in the next *Message!* window. Again the  $L^*a^*b^*$  values matching the RAL5024-P from the file *RAL Plastic Plate measured with Hunter Lab - 45°\_0°* are entered into the SETVALUE TABLE and the current XYZ values of the color sensor into the ACTUAL XYZ VALUE TABLE. The software now inquires whether it should be calibrated to another plastic card. Another mouse click on the Yes button and the next RAL plastic card can be entered: **RAL9011-P**.

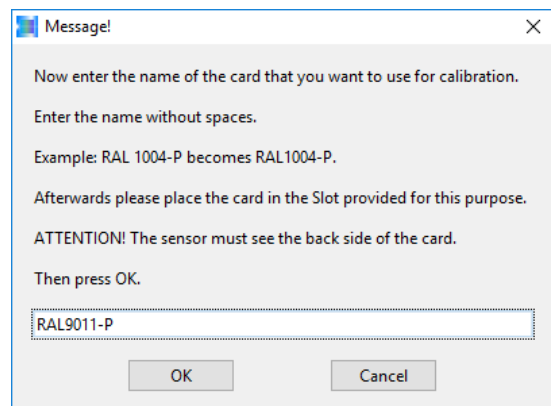
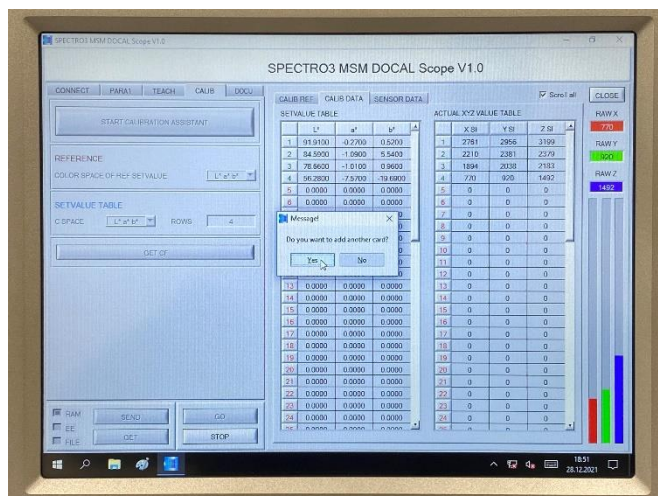
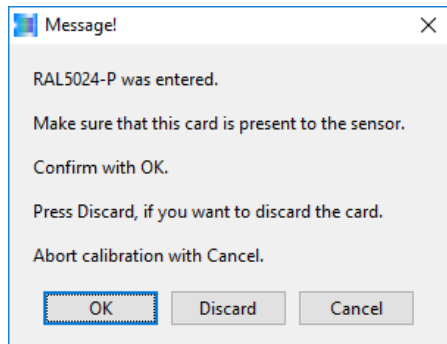

Now the RAL5024-P calibration card must be removed from the calibration card holder and the RAL9011-P must be inserted. After a mouse click on the **OK** button the following *Message!* opens:



After further mouse click on the **OK** button the  $L^*a^*b^*$  values are transferred from the file into the SETVALUE TABLE and the XYZ values from the color sensor into the ACTUAL XYZ VALUE TABLE for RAL9011-P.

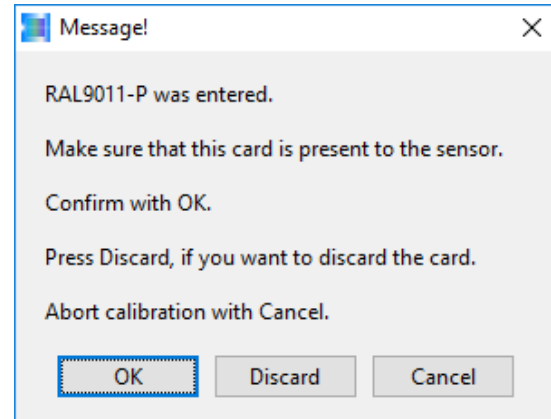

The values are entered in the 5th row of the respective table:

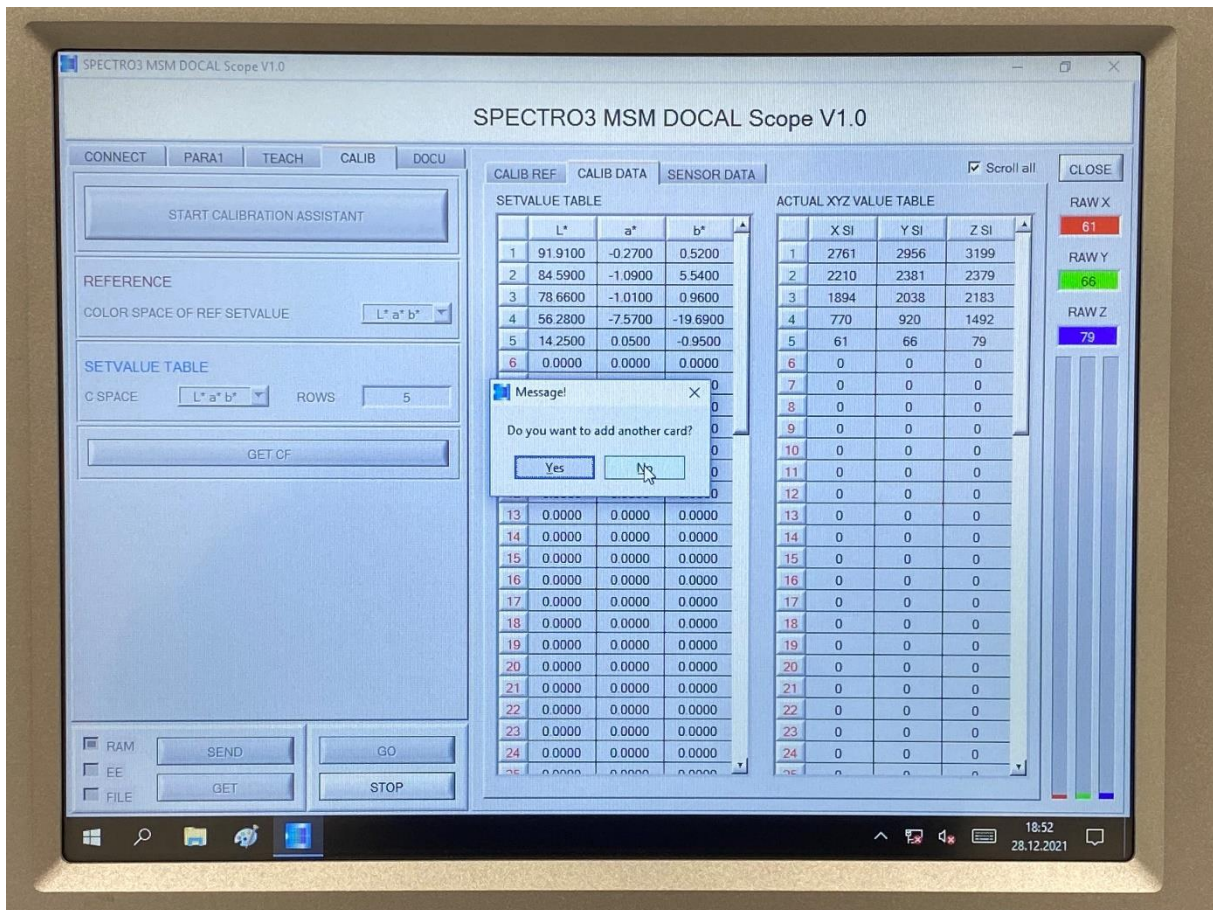

Now, in our example, we are through with the calibration cards, thus in the *Message!* window a mouse click on the *No* button can take place:

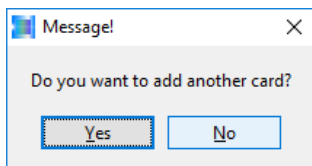

Click on *No*.

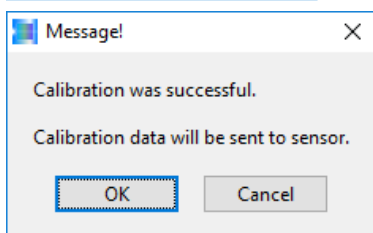

Click on *OK*.

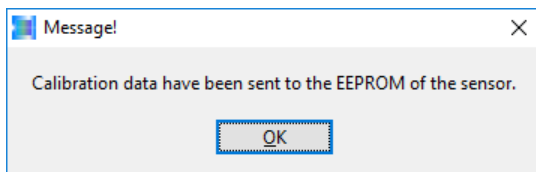

Click on *OK*.

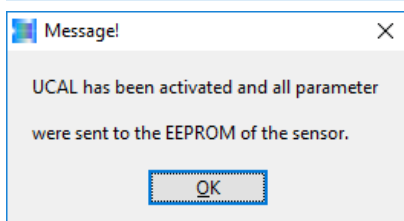

Click on *OK*.

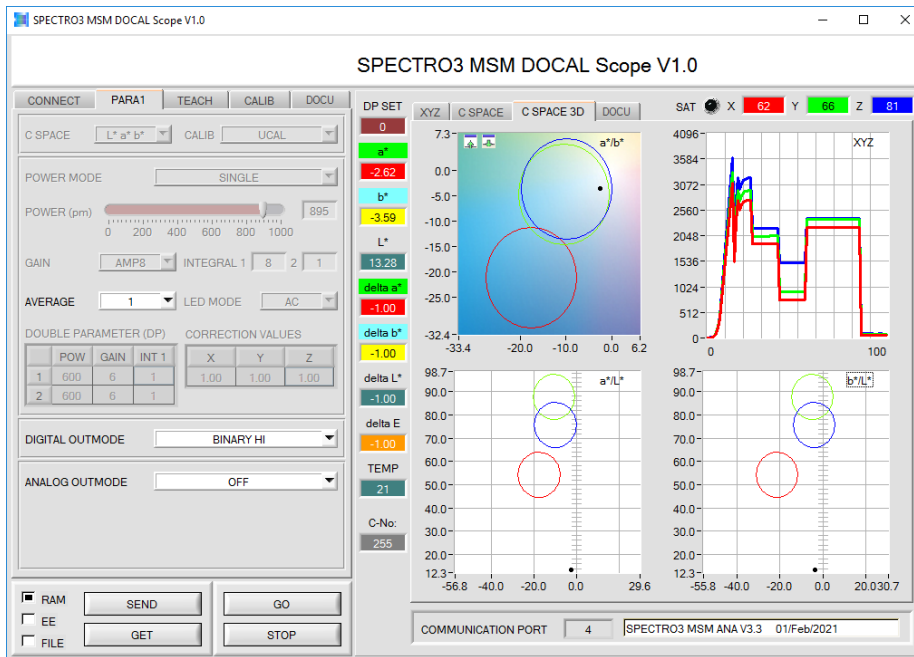

The SPECTRO-3-0°/45°-MSM-ANA-P laboratory measuring system is now calibrated.

## 6. Measurement of recycled samples with the SPECTRO-3-0°/45°-MSM-LAB-ANA-P laboratory instrument

The following pellet sample is to be measured with the laboratory device in our example:

Pastel blue similar to the reference RAL5024-P



The recyclate sample is quite similar to the RAL card RAL5024-P, which is why it was used here as a calibration card. The reference card does not necessarily have to match the recyclate sample exactly, but the accuracy of the measuring system is increased if reference

cards are used during calibration which are close in color to the recyclate samples. First, however, the calibration card holder unit must be converted. To do this, first remove any calibration card that may still be present. The pellet hopper unit can then be easily flanged to the calibration card holder unit. After opening the pellet sample container, pour the pellets completely into the funnel and place the empty sample container below the pellet hopper unit in the recess provided for this purpose.

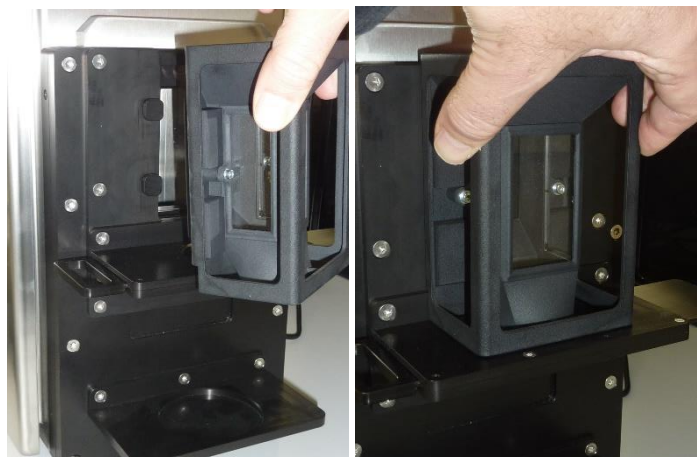

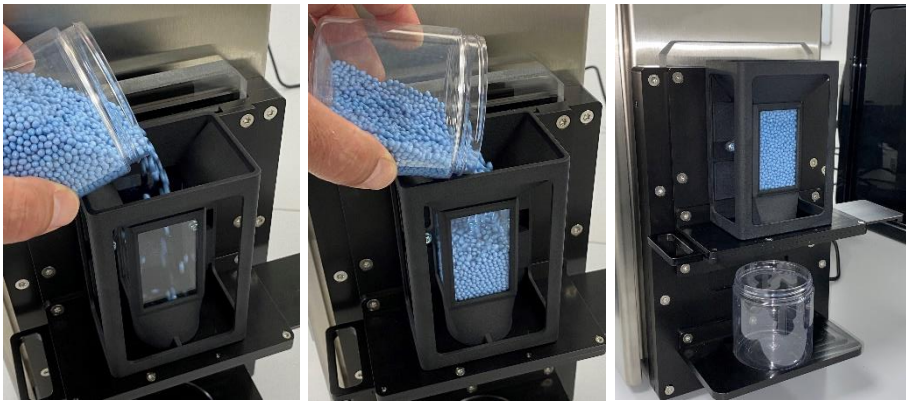

After placing the pellet sample, the TEACH menu item of the SPECTRO3 MSM DOCAL Scope V1.0 should be selected. The teach table should be reset first. This can be done with a mouse click on

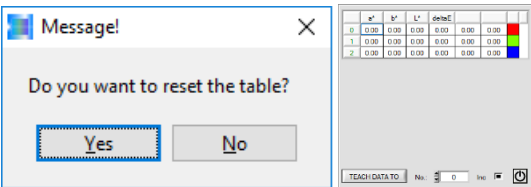

the reset button. Then click Yes on the button that opens and the entries in the teach table will be deleted.

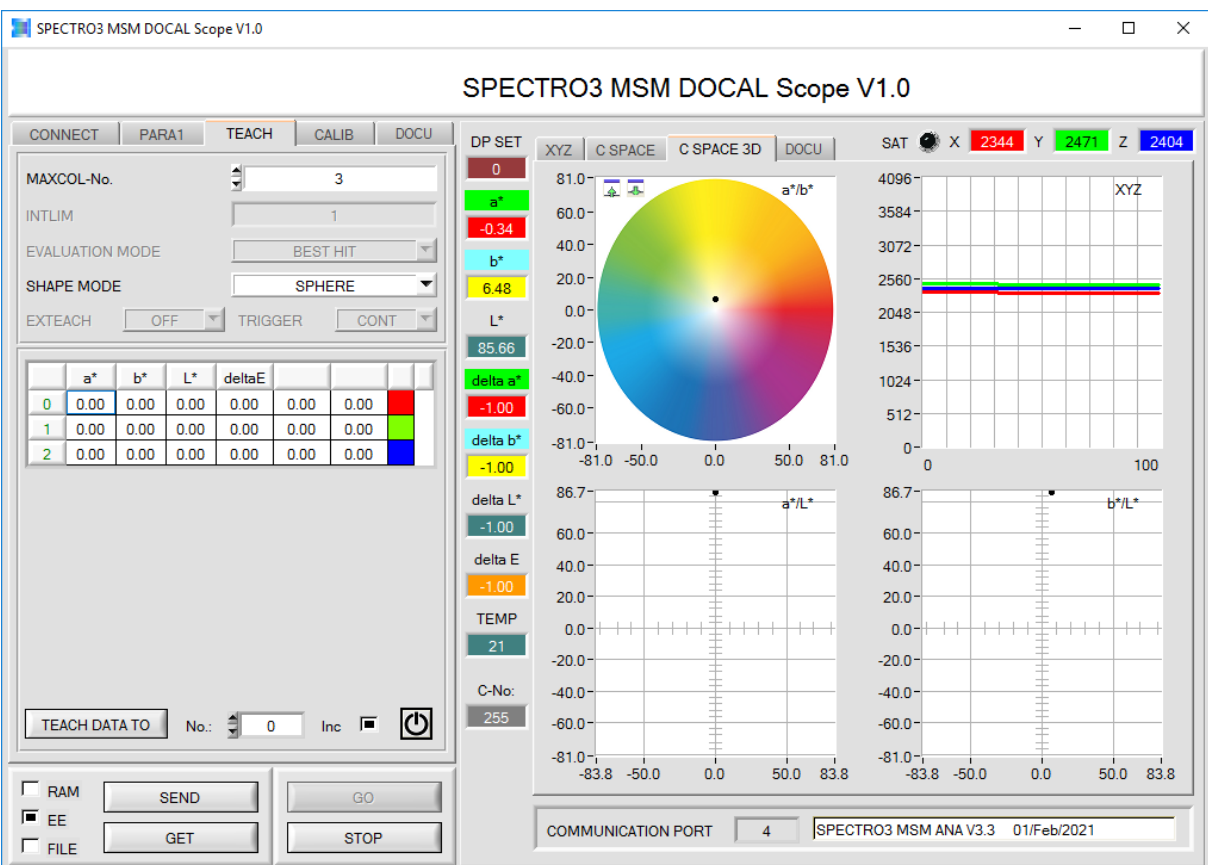

The  $L^*a^*b^*$  color values of the pellet sample can now be stored in the teach table by clicking on the TEACH DATA TO button. Note that the space (line number) provided in the table must still be specified (in our case for Pastel Blue the No.: 1). With the SPECTRO-3-0°/45°-MSM-LAB-ANA-P, three different pellet samples can be entered into the table. For the SPECTRO-3-0°/45°-MSM-LAB-DIG-P, the number of available table entries increases to 31. In the case of our pellet sample Pastel Blue thus:  $L^*=61.69$   $a^*=-7.22$   $b^*=-20.24$ , deltaE indicates that up to a color deviation of  $dE=10$  the  $dL^*$ ,  $da^*$  and the  $db^*$  - value, i.e. the respective deviation in  $L^*$ ,  $a^*$  and  $b^*$  from the taught-in reference is displayed. deltaE is set to 10 as default value but can be changed later if required. If the current color value meets the conditions of several table entries, the BEST HIT method is used (closest table entry to the current color value).

	a*	b*	L*	deltaE			
0	-0.25	6.47	85.69	10.00	0.00	0.00	Red
1	-7.22	-20.24	61.69	10.00	0.00	0.00	Green
2	0.00	0.00	0.00	0.00	0.00	0.00	Blue



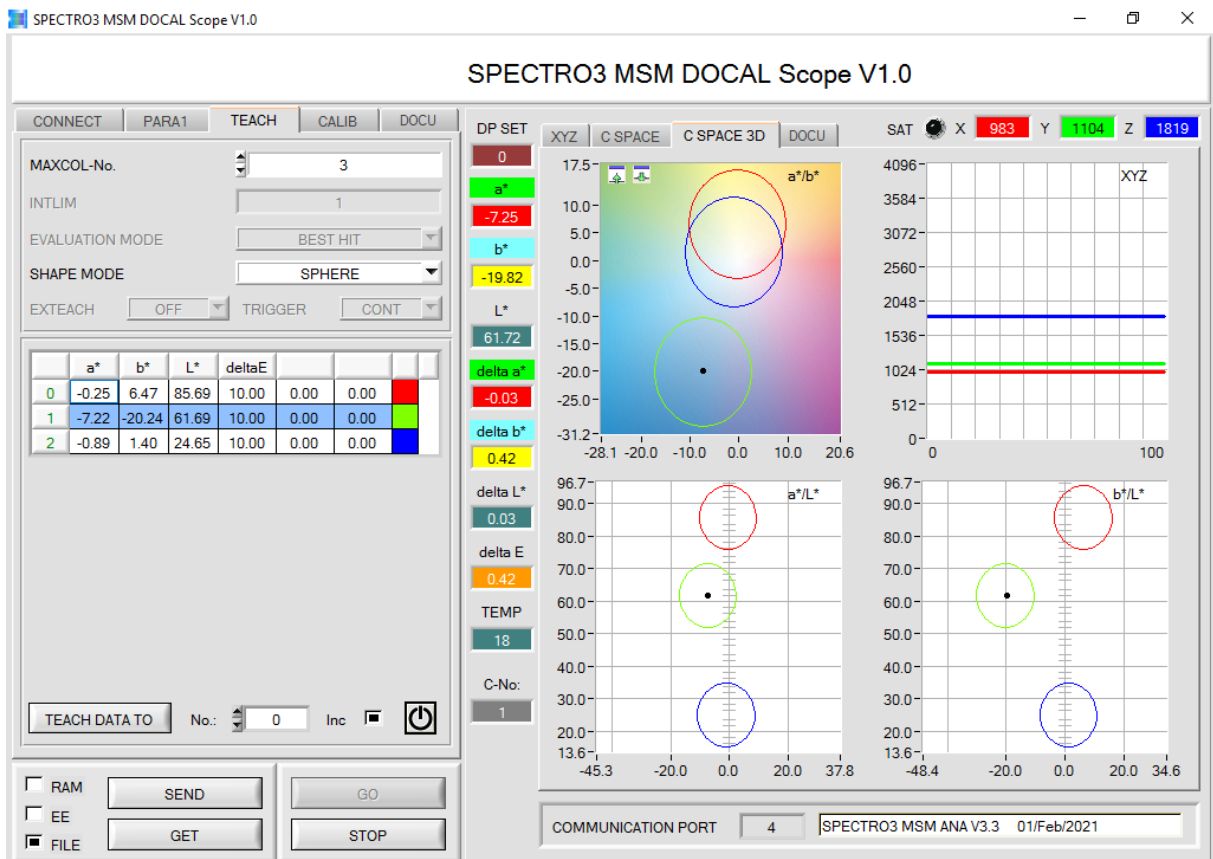

After the reference values have been entered in the teach table, you can switch to the DOCU menu item. First a file should be created, click the SELECT RECORD FILE button and enter the file name: E:\DOCAL\RecordFile\_PASTEL\_BLUE\_RECYCLATE\_038\_II.dat

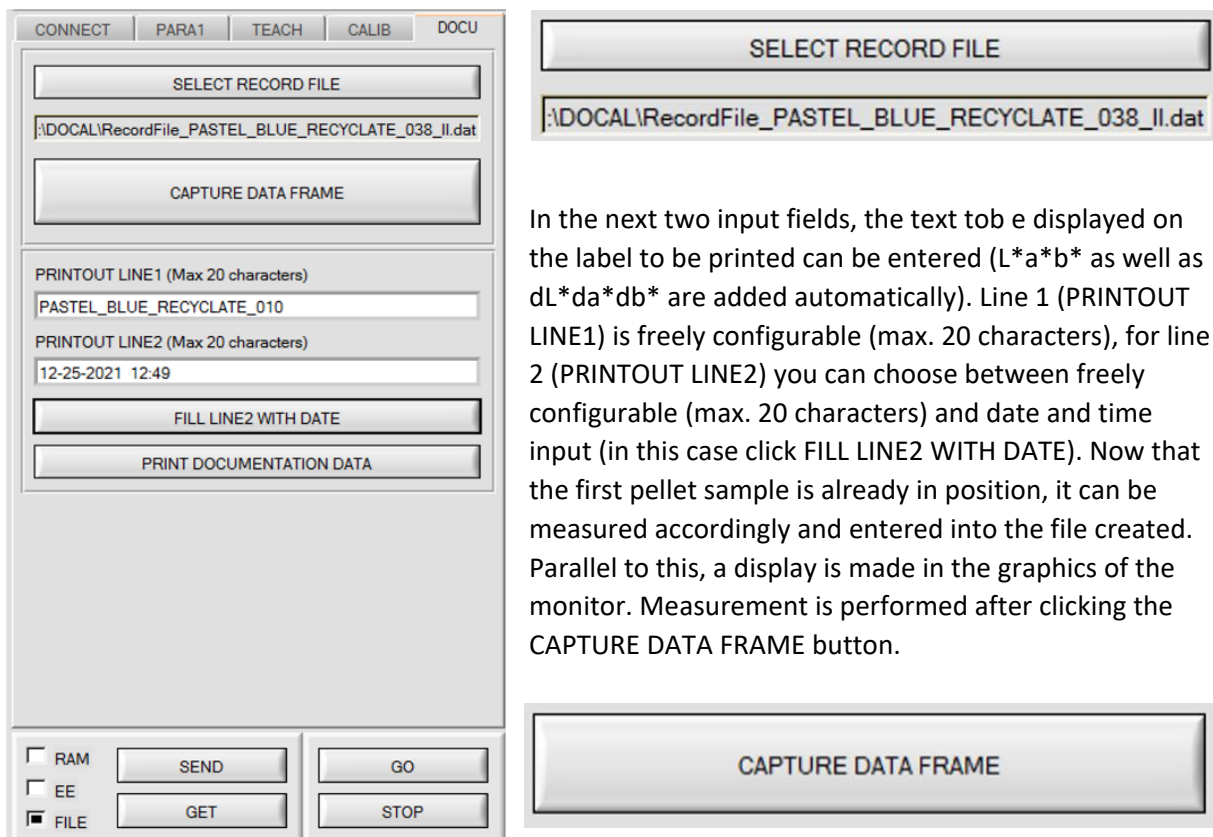

In the next two input fields, the text to be displayed on the label to be printed can be entered ( $L^*a^*b^*$  as well as  $dL^*da^*db^*$  are added automatically). Line 1 (PRINTOUT LINE1) is freely configurable (max. 20 characters), for line 2 (PRINTOUT LINE2) you can choose between freely configurable (max. 20 characters) and date and time input (in this case click FILL LINE2 WITH DATE). Now that the first pellet sample is already in position, it can be measured accordingly and entered into the file created. Parallel to this, a display is made in the graphics of the monitor. Measurement is performed after clicking the CAPTURE DATA FRAME button.

The graphic on the monitor (right side of the screen) looks like this after the mouse click on CAPTURE DATA FRAME:

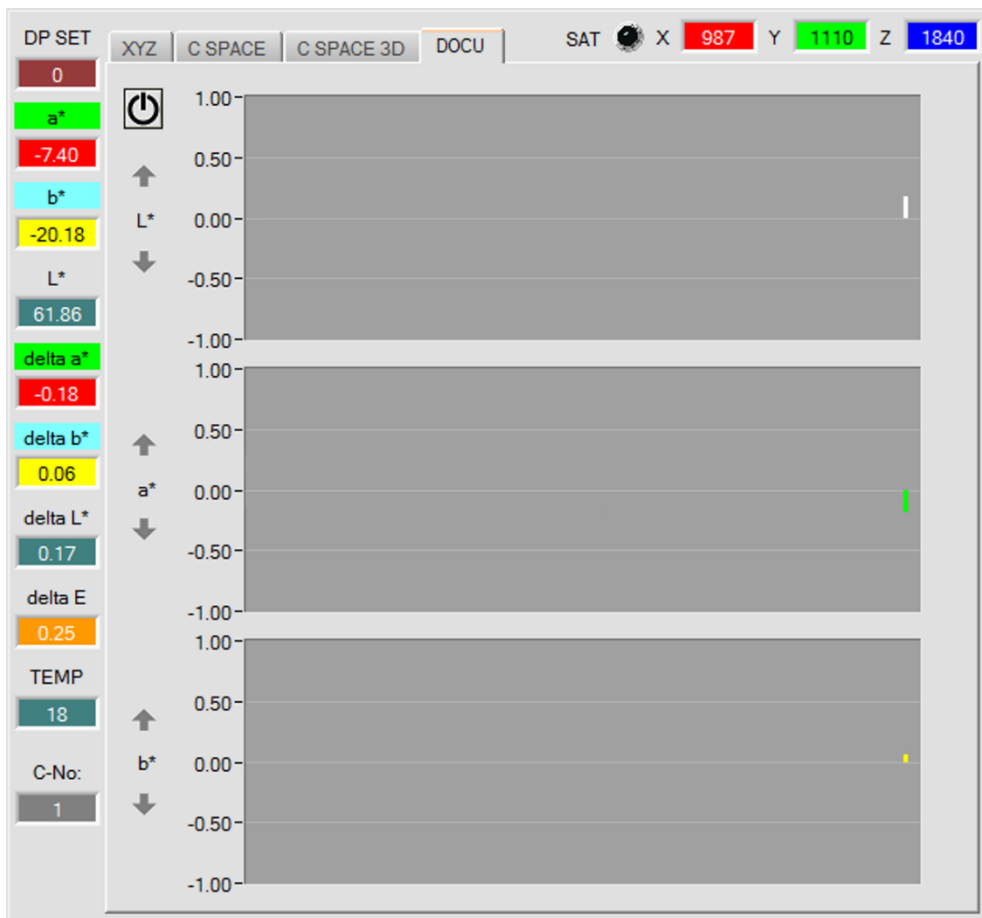

On the right of the graph are the individual columns for  $dL^*$  (white if the deviation is in the positive range, but black if the deviation is in the negative range),  $da^*$  (red if  $da^*$  is positive and green if  $da^*$  is negative),  $db^*$  (yellow if  $db^*$  is positive and blue if  $db^*$  is negative). The deviation is determined in relation to the applicable  $L^*a^*b^*$  value stored in the table. In our example thus the entry in line 1.

	a*	b*	L*	deltaE			
0	-0.25	6.47	85.69	10.00	0.00	0.00	red
1	-7.22	-20.24	61.69	10.00	0.00	0.00	green
2	0.00	0.00	0.00	0.00	0.00	0.00	blue

$$dL^* = 61.86 - 61.69 = 0.17 \quad da^* = -7.40 - (-7.22) = -0.18 \quad db^* = -20.18 - (-20.24) = 0.06$$

The label is created by clicking the PRINT DOCUMENTATION DATA button:

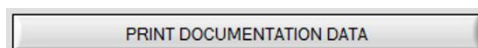

The following message will then appear on the screen:

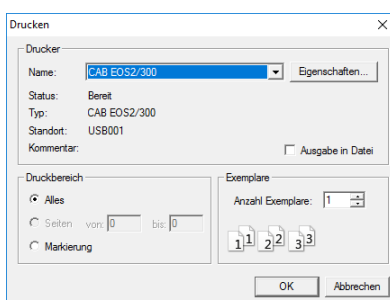

After clicking the *OK* button, the printout is made on the label printer and at the same time a message about the print process appears on the screen:

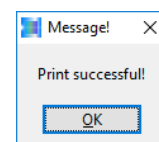

The label can now be affixed to the pellet sample container.



The measuring process can be carried out as often as required; one entry is made in the file created for each pellet sample:

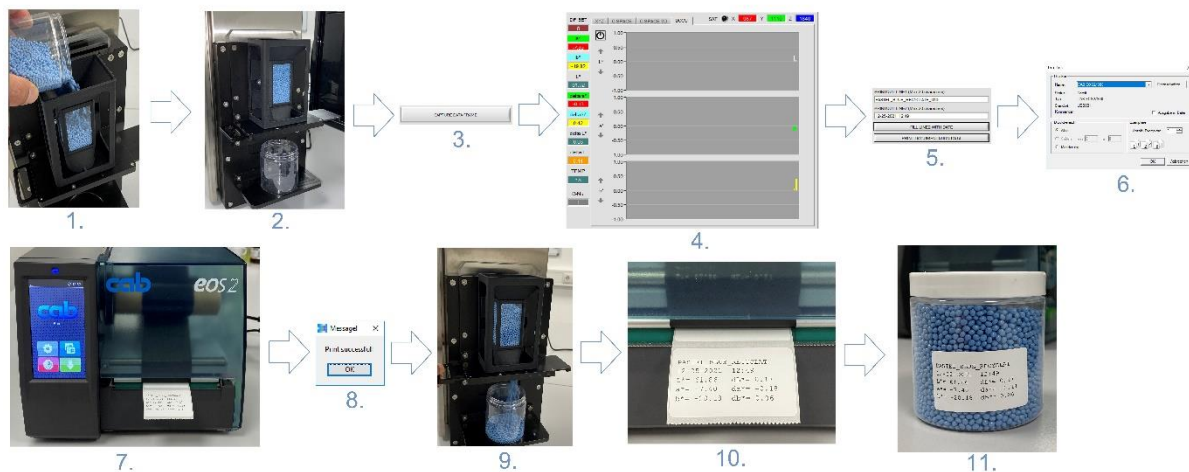

1. After another pellet sample has been taken, the pellets are filled into the pellet hopper unit.
2. Placing now empty pellet sample container in the recess provided for this purpose below the pellet hopper unit.
3. Activation of the measurement by click on the CAPTURE DATA FRAME software button.
4. In the right part of the software interface the current L\*a\*b\* values and the dE value are displayed numerically as well as graphically. In addition, the values are saved in the selected file together with the time and date.
5. In line 1 on the label to be created, text but also numbers and special characters can be entered. Line 2 can be used in the same way as line 1, or the date and the time can be entered (FILL LINE2 WITH DATE).
6. By clicking on the OK software button, the label printer will be prompted to create the label.
7. The label will be created on the label printer.
8. A message is displayed, that the printing process was successful.
9. The pellets can now be removed from the pellet hopper unit by pulling the slider. The pellets are thereby filled into the already placed, empty pellet sample container. Now only the lid has been screwed on and
10. Peeling the label from the backing material.
11. Sticking the label onto the pellet sample container.

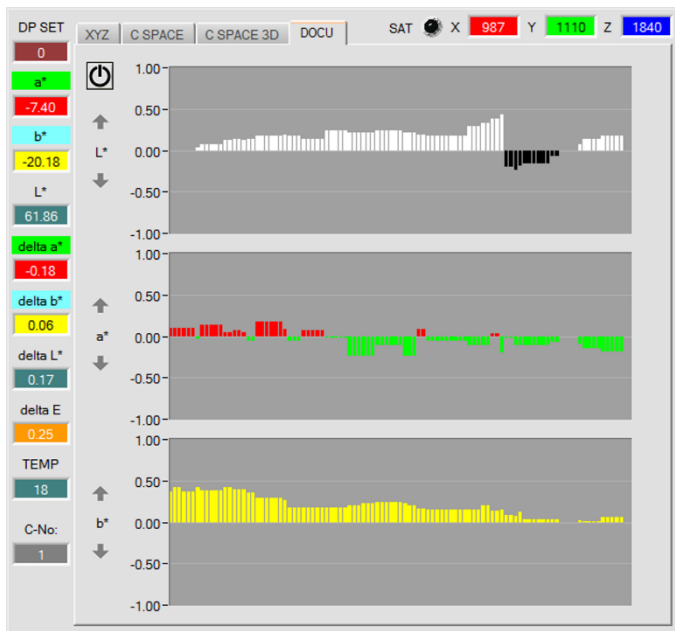

2nd Measurement

Taking another pellet sample from the production:

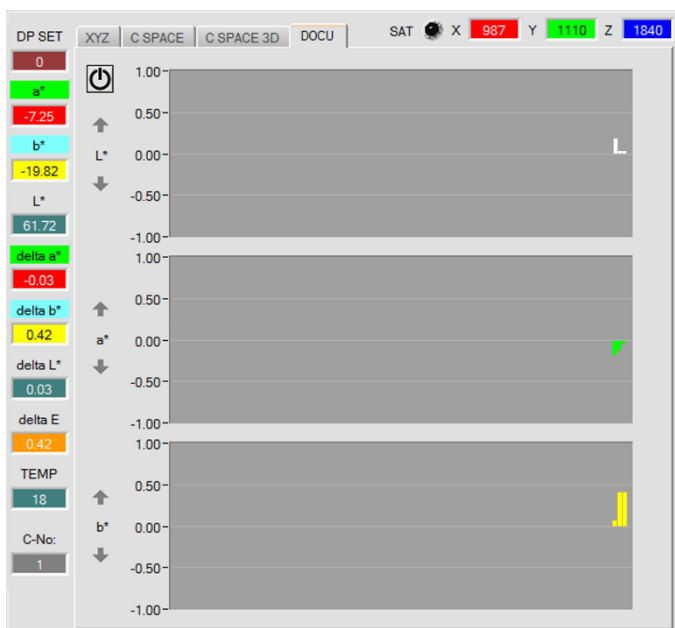
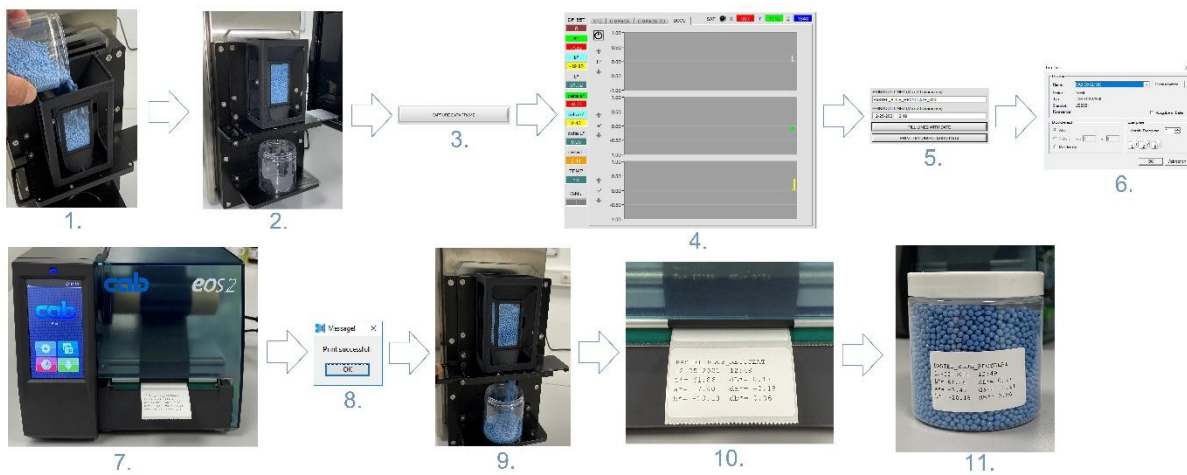

3rd Measurement

After 100 measurements, the following picture emerges:

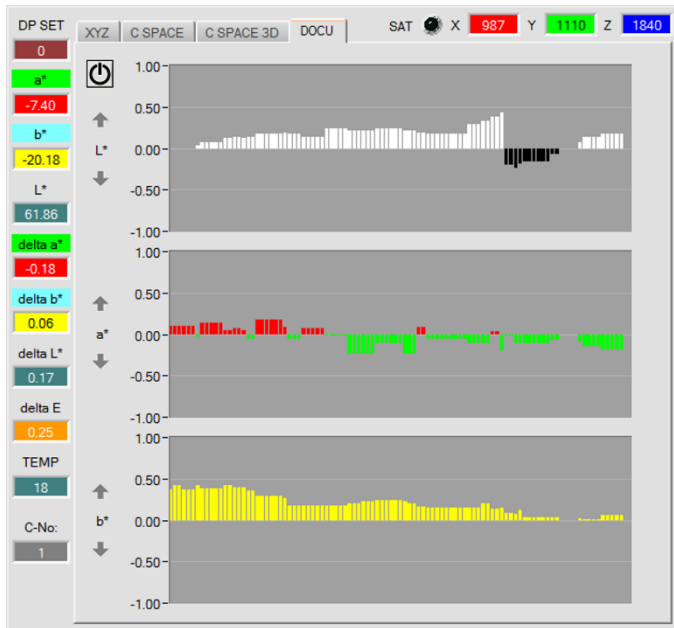

A look at the file using the text editor gives the following picture:

RecordFile\_PASTEL\_BLUE\_RECYCLATE\_038\_II - Editor

Datei Bearbeiten Format Ansicht ?

Record results of: SPECTRO3 MSM DOCAL Scope V1.0

DATE	TIME	X	Y	Z	L*	a*	b*	delta E	delta L*	delta a*	delta b*	COLOI	
12-25-2021	12:39:10	983	1103	1819	61.688	-7.122	-19.870	0.382	0.000	0.097	0.369	1	18
12-25-2021	12:39:16	983	1103	1817	61.688	-7.122	-19.820	0.429	0.000	0.097	0.418	1	18
12-25-2021	12:39:18	983	1103	1817	61.688	-7.122	-19.820	0.429	0.000	0.097	0.418	1	18
12-25-2021	12:39:20	983	1103	1819	61.688	-7.122	-19.870	0.382	0.000	0.097	0.369	1	18
12-25-2021	12:39:21	983	1103	1819	61.688	-7.122	-19.870	0.382	0.000	0.097	0.369	1	18
12-25-2021	12:39:22	983	1103	1819	61.688	-7.122	-19.870	0.382	0.000	0.097	0.369	1	18
12-25-2021	12:39:23	983	1104	1819	61.717	-7.249	-19.819	0.422	0.029	-0.030	0.420	1	18
12-25-2021	12:39:44	986	1106	1823	61.761	-7.084	-19.854	0.414	0.073	0.134	0.385	1	18
12-25-2021	12:39:45	986	1106	1823	61.761	-7.084	-19.854	0.414	0.073	0.134	0.385	1	18
12-25-2021	12:39:46	986	1106	1823	61.761	-7.084	-19.854	0.414	0.073	0.134	0.385	1	18
12-25-2021	12:39:46	986	1106	1823	61.761	-7.084	-19.854	0.414	0.073	0.134	0.385	1	18
12-25-2021	12:39:47	986	1106	1823	61.761	-7.084	-19.854	0.414	0.073	0.134	0.385	1	18
12-25-2021	12:39:52	987	1108	1824	61.805	-7.178	-19.815	0.442	0.117	0.041	0.424	1	18
12-25-2021	12:39:53	987	1108	1824	61.805	-7.178	-19.815	0.442	0.117	0.041	0.424	1	18
12-25-2021	12:39:54	988	1109	1827	61.827	-7.144	-19.851	0.419	0.140	0.075	0.388	1	18
12-25-2021	12:39:55	988	1109	1827	61.827	-7.144	-19.851	0.419	0.140	0.075	0.388	1	18
12-25-2021	12:39:56	987	1108	1825	61.805	-7.178	-19.839	0.418	0.117	0.041	0.399	1	18
12-25-2021	12:39:59	987	1109	1828	61.827	-7.273	-19.887	0.382	0.140	-0.054	0.351	1	18
12-25-2021	12:40:00	987	1109	1828	61.827	-7.273	-19.887	0.382	0.140	-0.054	0.351	1	18
12-25-2021	12:40:00	990	1110	1832	61.857	-7.045	-19.948	0.379	0.169	0.173	0.291	1	18
12-25-2021	12:40:01	990	1110	1832	61.857	-7.045	-19.948	0.379	0.169	0.173	0.291	1	18
12-25-2021	12:40:02	990	1110	1832	61.857	-7.045	-19.948	0.379	0.169	0.173	0.291	1	18
12-25-2021	12:40:03	990	1110	1832	61.857	-7.045	-19.948	0.379	0.169	0.173	0.291	1	18
12-25-2021	12:40:04	990	1110	1832	61.857	-7.045	-19.948	0.379	0.169	0.173	0.291	1	18
12-25-2021	12:40:09	990	1111	1834	61.879	-7.140	-19.971	0.338	0.191	0.078	0.268	1	18
12-25-2021	12:40:10	988	1110	1836	61.857	-7.271	-20.058	0.253	0.169	-0.052	0.180	1	18
12-25-2021	12:40:11	988	1110	1836	61.857	-7.271	-20.058	0.253	0.169	-0.052	0.180	1	18
12-25-2021	12:40:11	988	1110	1836	61.857	-7.271	-20.058	0.253	0.169	-0.052	0.180	1	18
12-25-2021	12:40:12	988	1109	1834	61.827	-7.144	-20.060	0.239	0.140	0.075	0.179	1	18
12-25-2021	12:40:13	988	1109	1834	61.827	-7.144	-20.060	0.239	0.140	0.075	0.179	1	18
12-25-2021	12:40:14	988	1109	1834	61.827	-7.144	-20.060	0.239	0.140	0.075	0.179	1	18
12-25-2021	12:40:15	988	1109	1834	61.827	-7.144	-20.060	0.239	0.140	0.075	0.179	1	18

The file can also be opened with Excel:

